

COMSOL CONFERENCE EUROPE

Milan, 10-12 October

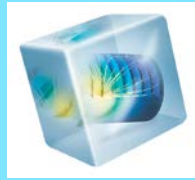
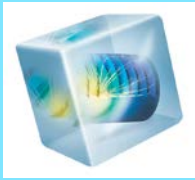

Dynamic Behavior of Cable Supported Bridges Affected by Corrosion Mechanisms under Moving Loads

Lonetti P., Pascuzzo A., Sarubbo R.

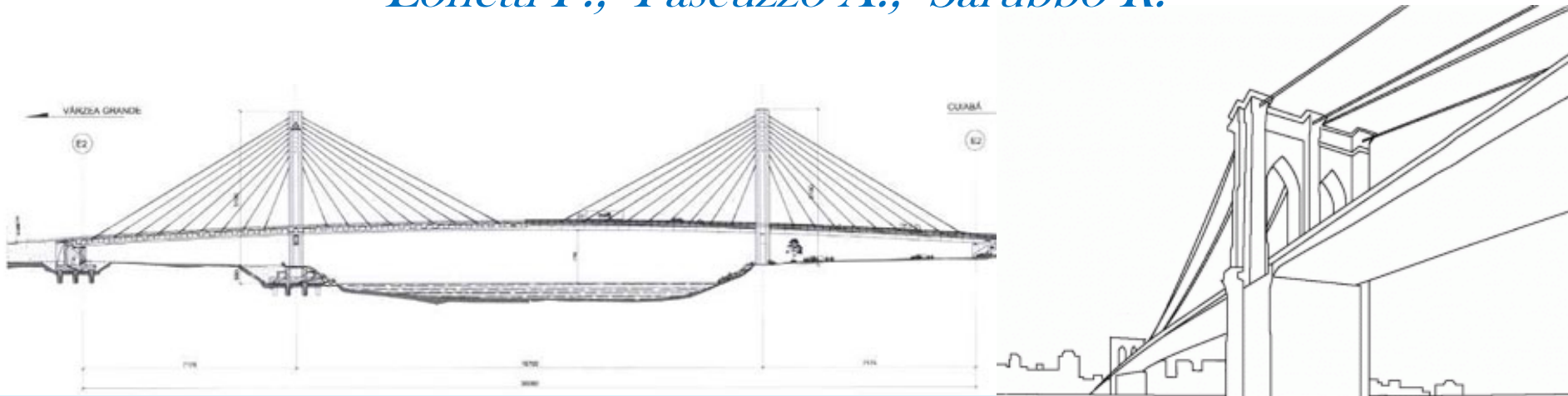

Department of Structural Engineering

University of Calabria, Via P. Bucci, Cubo39-B, 87030, Rende, Cosenza, Italy

INTRODUCTION TO LONG SPAN CABLE SUPPORTED BRIDGE

TYPES OF BRIDGES

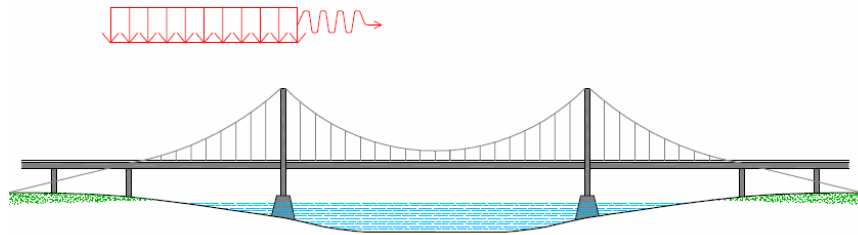

Suspended Bridge

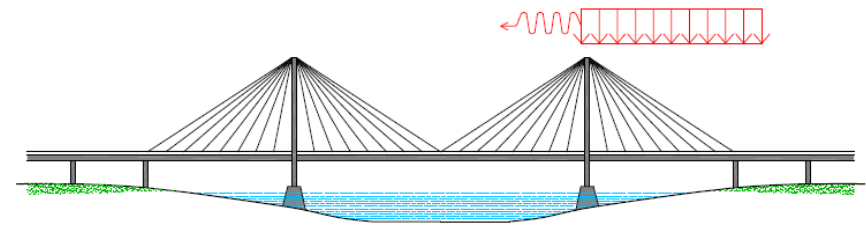

Cable-Stayed Bridge

KEY FEATURES AND STRUCTURAL PROBLEMS

- Long slender structures
- Live loads are comparable with the dead load
- High dynamic amplification effects on the structure are expected
- Initial Configuration: Specific initial stresses in the suspension system to ensure that the deck stays in the undeformed configuration during the application of the dead loads
- Several damage phenomena, which produce a reduction of the mechanical properties of the bridge constituents



MOTIVATION AND SUMMARY OF THE WORK

AIM OF THE WORK

Investigate the influence on cable supported bridge structures of corrosion mechanisms in the cable-stayed and suspension systems

SUMMARY

- Review the main equations of the bridge in a dynamic framework
- Analyze the structural behavior of cable system reproducing local vibration effects, by means of a geometric non-linear approach and an explicit damage law for the corrosion mechanisms.
- Reproduce accurately the inertial description of the moving loads including non-standard forces produced relative motion with the girder
- Develop the finite element implementation and a parametric study to quantify numerically the dynamic amplification effects produced by the moving loads for the cases of damaged and undamaged structures



BRIDGE FORMULATION AND ASSUMPTIONS

OBJECTIVES AND ASSUMPTIONS OF THE MODEL

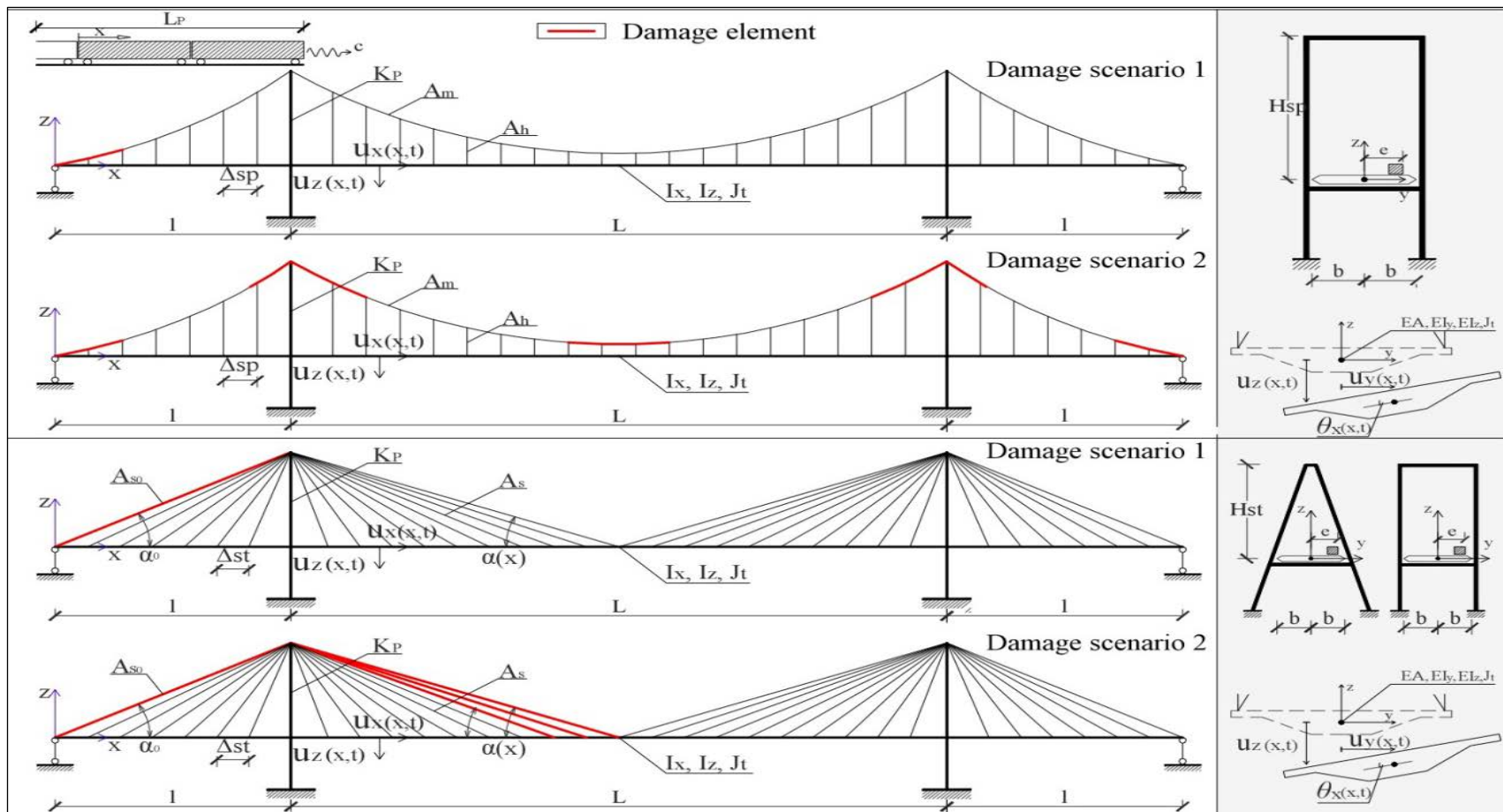

- Dynamic behavior and local vibration effects of the cable system
- Moving loads and girder deformation
- Simulation of the damage mechanisms in the cable system

INITIAL CONFIGURATION OF THE BRIDGE: "OPTIMIZATION PROBLEM"

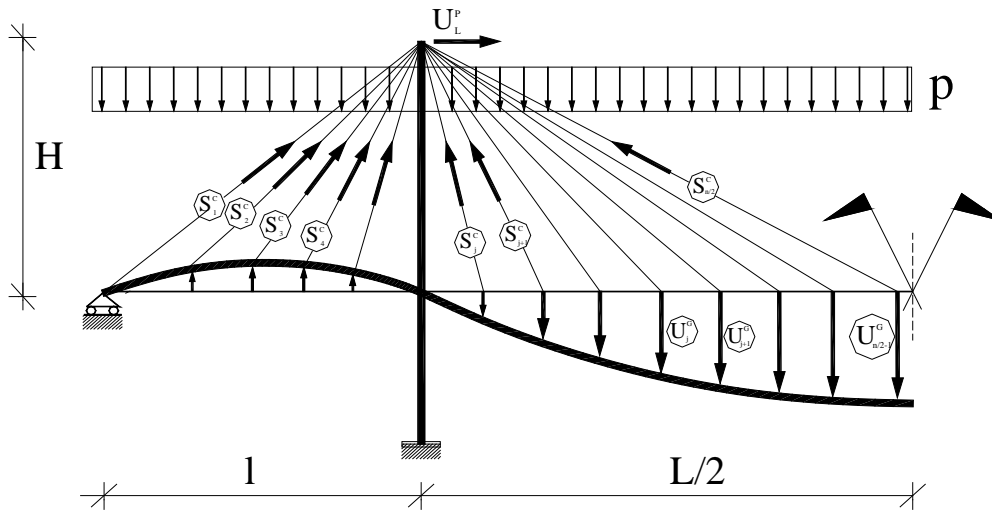

Vector objective function:

$$\underline{U}^T = [U_L^P, U_1^G, \dots, U_{n-3}^G, U_{n-2}^G],$$

Vector control variable

$$\underline{S}^T = [S_1^C, S_2^C, \dots, S_{n_c-1}^C, S_n^C]$$

General optimization problem

$$\begin{cases} \min_{\underline{S}} \|\underline{U}(\underline{S})\| \\ S_i > 0 \end{cases} \quad \Rightarrow$$

Iterative method

$$\underline{U}(\underline{S}_k + \Delta \underline{S}_k, p) = \underline{U}(\underline{S}_k, p) + \frac{d\underline{U}}{d\underline{S}} \Big|_{(\underline{S}_k, p)} \Delta \underline{S}_k + o\|\Delta \underline{S}_k\|^2 \cong 0$$

$$\Delta \underline{S}_k = - \left[\frac{d\underline{U}}{d\underline{S}} \Big|_{(\underline{S}_k, p)} \right]^{-1} \underline{U}(\underline{S}_k, p) \quad \rightarrow \quad \underline{S}_{k+1} = \underline{S}_k + \Delta \underline{S}_k$$

FORMULATION OF THE CABLE SYSTEM

Initial deformed configuration

$$H \frac{d^2 z}{dx^2} = -mg \frac{ds}{dx}$$

Geometric nonlinearity based on the Green-Lagrange strain measure

$$\boldsymbol{\varepsilon}_n = \underset{\sim}{t}^T \boldsymbol{\varepsilon}_{gT} \underset{\sim}{t} \quad \varepsilon_{ijT} = \frac{1}{2} \left(\left. \frac{\partial u_i}{\partial x_j} \right|_T + \left. \frac{\partial u_j}{\partial x_i} \right|_T + \left. \frac{\partial u_k}{\partial x_i} \right|_T \cdot \left. \frac{\partial u_k}{\partial x_j} \right|_T \right)$$

Dynamic equations of the i-th stay

$$\frac{d}{dX_1} \left[N_1 + N_1 \frac{dU_1}{dX_1} \right] - b_1 - \mu_c \ddot{U}_1 = 0, \quad \frac{d}{dX_1} \left[N_1 \frac{dU_2}{dX_1} \right] - \mu_c \ddot{U}_2 = 0, \quad \frac{d}{dX_1} \left[N_1 \frac{dU_3}{dX_1} \right] - b_2 - \mu_c \ddot{U}_3 = 0$$

Localized elastic damage based on the CDM approach

$$A_{eff} = A_0 - A^*$$

Effective Area

$$D = \frac{A_{eff}}{A_0} = \frac{A_0 - A^*}{A_0} \quad \text{with } D \in [0,1]$$

Damage definition: Corrosion ratio

$$\sigma_{eff} = \frac{T}{A_{eff}} \Rightarrow \sigma_{eff} = \frac{\sigma}{1-D}$$

Effective Stress

$$\varepsilon = \frac{\sigma}{E_{eff}} = \frac{\sigma_{eff}}{E} = \frac{\sigma}{(1-D)E}$$

Lemaitre's equivalent strain principle

$$E_{eff} = \frac{A_{eff}}{A_0} E$$

Effective modulus of elasticity

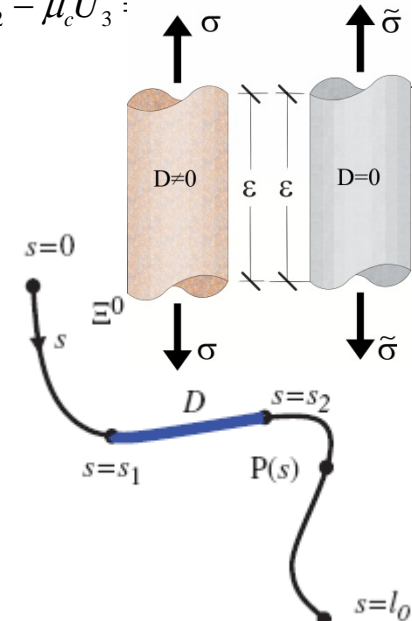
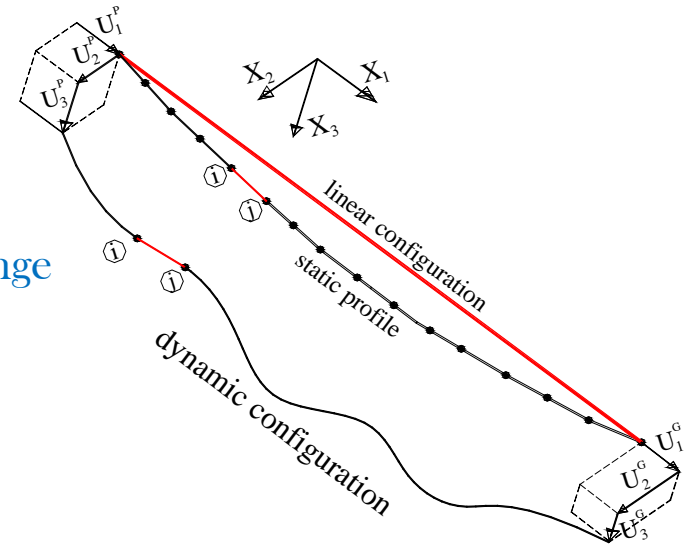

FORMULATION OF THE MOVING SYSTEM

Moving load description

Balance of linear momentum

$$dR_{X_3} = dX_1 \left\{ \lambda g + \frac{d}{dt} \left[\lambda \frac{d\dot{\bar{U}}_3^m}{dt}(s(t)) \right] \right\} \Big|_{s=X_1}$$

Selfweight loads

Transient loads (mass and path time dependent)

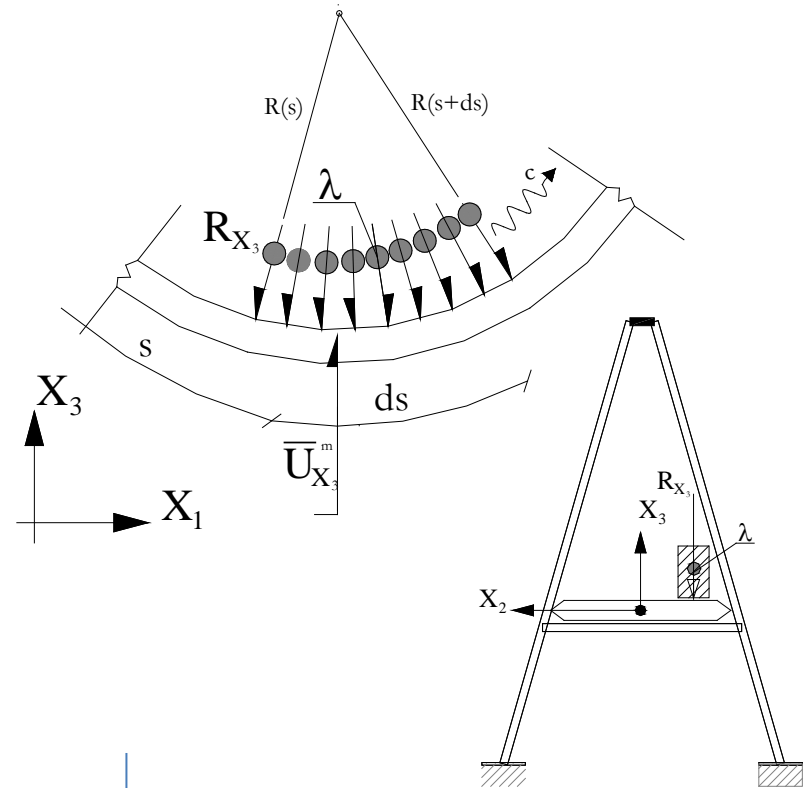

Governing equations of the girder

$$dR_{X_3} = dX_1 \left\{ \lambda g + \frac{d\lambda}{dt} \frac{d\dot{\bar{U}}_3^m}{dt}(s(t)) + \lambda \frac{d^2\dot{\bar{U}}_3^m}{dt^2}(s(t)) \right\} \Big|_{s=X_1}$$

$$\frac{d^2\bar{U}_3^m}{dt^2} = \frac{d}{dt} \left[\frac{\partial \bar{U}_3^m}{\partial t} + \frac{\partial \bar{U}_3^m}{\partial t} \frac{\partial s(t)}{\partial t} \right] = \frac{\partial^2 \bar{U}_3^m}{\partial t^2} + 2c \frac{\partial^2 \bar{U}_3^m}{\partial t \partial s} + c \frac{\partial^2 \bar{U}_3^m}{\partial s^2}$$

Time dependent derivative rule

Bridge kinematic

$$\bar{U}_3^m(X_2, X_3, t) = U_3(X_1, t) + \Phi_1(X_1, t)e$$



GIRDER-MOVING SYSTEM EQUATIONS (PDE)

Moving loads equations

$$p_{X_3} = \frac{dR_{X_3}}{dX_1} = \lambda g + \frac{d\lambda}{dt} \left[\left(\frac{\partial U_3}{\partial t} + e \frac{\partial \Phi_1}{\partial t} \right) + c \left(\frac{\partial U_3}{\partial X_1} + e \frac{\partial \Phi_1}{\partial X_1} \right) \right] + \lambda \left[\frac{\partial^2 U_3}{\partial t^2} + 2c \frac{\partial^2 U_3}{\partial t \partial X_1} + c \frac{\partial^2 U_3}{\partial X_1^2} \right] + \lambda e \left[\frac{\partial^2 \Phi_1}{\partial t^2} + 2c \frac{\partial^2 \Phi_1}{\partial t \partial X_1} + c \frac{\partial^2 \Phi_1}{\partial X_1^2} \right]$$

$$p_{X_1} = \frac{dR_{X_1}}{dX_1} = \frac{d\lambda}{dt} \left[\frac{\partial U_1}{\partial t} + c \frac{\partial U_1}{\partial X_1} \right] + \lambda \left[\frac{\partial^2 U_1}{\partial t^2} \right]$$

$$p_{X_2} = \frac{dR_{X_2}}{dX_2} = \frac{d\lambda}{dt} \left[\frac{\partial U_2}{\partial t} + c \frac{\partial U_2}{\partial X_1} \right] + \lambda \left[\frac{\partial^2 U_2}{\partial t^2} \right]$$

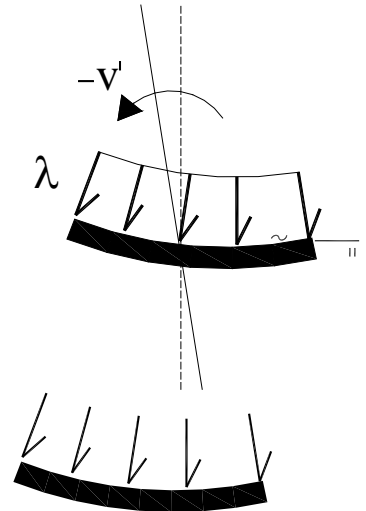
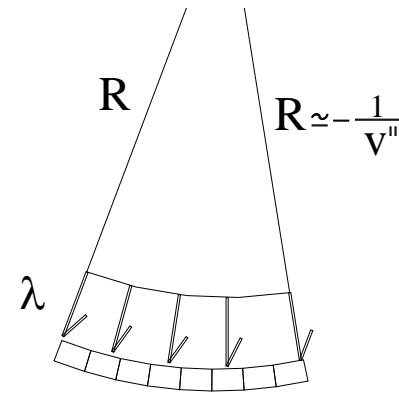

Girder Equilibrium equations

$$EA \frac{d}{dX_1} \left\{ U_{1,X_1} + \frac{1}{2} \left[U_{1,X_1}^2 + U_{2,X_1}^2 + U_{3,X_1}^2 \right] \right\} - \mu_G \ddot{U}_1 + p_{X_1} = 0,$$

$$-EI \frac{d^4 U_3}{dX_1^4} + EA \frac{d}{dX_1} \left\{ \left[U_{1,X_1} + \frac{1}{2} \left(U_{1,X_1}^2 + U_{2,X_1}^2 + U_{3,X_1}^2 \right) \right] U_{3,X_1} \right\} + \mu_G \ddot{U}_3 - \ddot{\Phi}_{2,X_1} I_{02} + p_{X_3} = 0$$

$$EI \frac{d^4 U_2}{dX_1^4} + \frac{d}{dX_1} \left(N_1 \frac{dU_2}{dX_1} \right) + \rho A \ddot{U}_2 - \ddot{\Phi}_{3,X_1} I_{03} + p_{X_2} = 0,$$

$$GJ_t \Phi_{1,X_1 X_1} - I_{01} \ddot{\Phi}_1 - \rho \left(e + \frac{\lambda_0}{\lambda} \right) g - e \frac{d\rho}{dt} \left[\frac{\partial \Phi_1}{\partial t} + c \frac{\partial \Phi_1}{\partial X_1} \right] - \rho e \left[\frac{\partial^2 \Phi_1}{\partial t^2} + 2c \frac{\partial^2 \Phi_1}{\partial t \partial X_1} + c \frac{\partial^2 \Phi_1}{\partial X_1^2} \right] = 0$$

VARIATIONAL FORMULATION AND FE IMPLEMENTATION



Girder Variational Equations

$$\begin{aligned}
 & \int_{l_e^i} N_1^G (1 + U_{1,X_1}^G) w_{1,X_1} dX_1 - \mu_c \int_{l_e^i} \ddot{U}_1^G w_1 dX_1 - \int_{l_e^i} b_1 w_1 dX_1 - \sum_{j=1}^2 N_{1j}^G U_{1j}^G = 0, \\
 & \int_{l_e^i} \left\{ M_2^G w_{2,X_1 X_1} - (N_1^G U_3^G)_{,X_1} w_{2,X_1} \right\} dX_1 - \mu_g \int_{l_e^i} \ddot{U}_3^G w_2 dX_1 - \lambda \int_{l_e^i} [-\bar{\delta}_1 + \bar{\delta}_2] (\dot{U}_3^G + c U_{3,X_1}^G) w_2 dX_1 + \\
 & - \lambda \int_{l_e^i} \bar{H}_1 \bar{H}_2 \left[(\ddot{U}_3^G + 2c \dot{U}_{3,X_1}^G + c^2 U_{3,X_1 X_1}^G) + g \right] w_2 dX_1 - \sum_{j=1}^2 T_{3j}^G U_{3j}^G - \sum_{j=1}^2 M_{2j}^G \Phi_{3j}^G = 0, \\
 & \int_{l_e^i} \left\{ M_3^G w_{3,X_1 X_1} - (N_1^G U_2^G)_{,X_1} w_{3,X_1} \right\} dX_1 - \mu_g \int_{l_e^i} \ddot{U}_2^G w_3 dX_1 - \sum_{j=1}^2 T_{2j}^G U_{2j}^G - \sum_{j=1}^2 M_{3j}^G \Phi_{2j}^G = 0, \\
 & \int_{l_e^i} M_1^G w_{4,X_1} dX_1 - I_{01} \int_{l_e^i} \ddot{\Phi}_1^G w_4 dX_1 - \lambda \left(e + \frac{\lambda_0}{\lambda} \right) g \int_{l_e^i} \bar{H}_1 \bar{H}_2 (\dot{\Phi}_1^G + 2c \dot{\Phi}_{1,X_1}^G + c^2 \Phi_{1,X_1 X_1}^G) w_4 dX_1 + \\
 & + \lambda \int_{l_e^i} [-\bar{\delta}_1 + \bar{\delta}_2] (\dot{\Phi}_1^G + c \Phi_{1,X_1}^G) w_4 dX_1 - \sum_{j=1}^2 M_{1j}^G \Phi_{1j}^G = 0,
 \end{aligned}$$

Girder element i-j

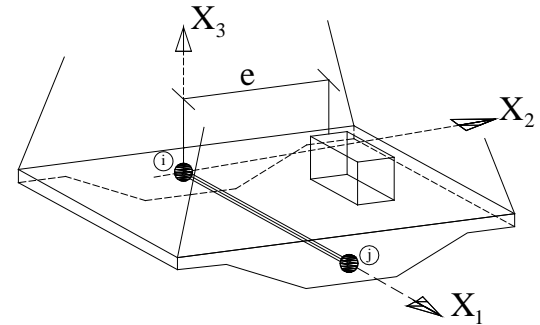

Non standard forces produced by the inertial description of the moving loads

VARIATIONAL FORMULATION AND F.E. IMPLEMENTATION

▣ Cable variational equations

$$\int_{l_e^i} (N_1^C + N_0^C) (1 + U_1^C) w_{1,x_1} dX_1 - \mu_c \int_{l_e^i} \ddot{U}_1^C w_1 dX_1 - \int_{l_e^i} b_1 w_1 dX_1 - \sum_{j=1}^2 N_{1j} U_{1j}^C = 0,$$

$$\int_{l_e^i} (N_1^C + N_0^C) w_{2,x_1} dX_1 - \mu_c \int_{l_e^i} \ddot{U}_2^C w_2 dX_1 - \sum_{j=1}^2 N_{1j}^C U_{2j}^C = 0,$$

$$\int_{l_e^i} (N_1^C + N_0^C) w_{3,x_1} dX_1 - \mu_c \int_{l_e^i} \ddot{U}_3^C w_3 dX_1 - \int_{l_e^i} b_3 w_3 dX_1 - \sum_{j=1}^2 N_{1j}^C U_{3j}^C = 0,$$

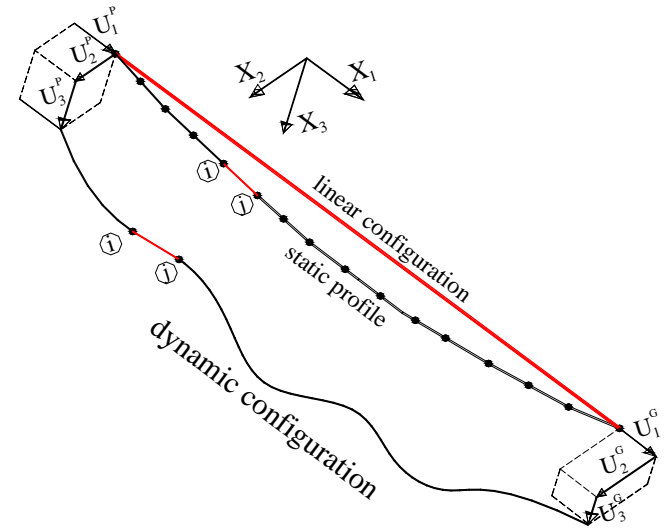

▣ Constraint equations: Girder-Pylons /Cable System

$$U_3^G(\underline{X}_{C_i}, t) - \Phi_1^G(\underline{X}_{C_i}, t) b = U_3^C(\underline{X}_{C_i}, t)$$

$$U_1^G(\underline{X}_{C_i}, t) + \Phi_3^G(\underline{X}_{C_i}, t) b = U_1^C(\underline{X}_{C_i}, t)$$

$$U_1^P(\underline{X}_P, t) = U_1^C(\underline{X}_P, t), U_2^P(\underline{X}_P, t) = U_2^C(\underline{X}_P, t), U_3^P(\underline{X}_P, t) = U_3^C(\underline{X}_P, t)$$

▣ Girder/Cable System

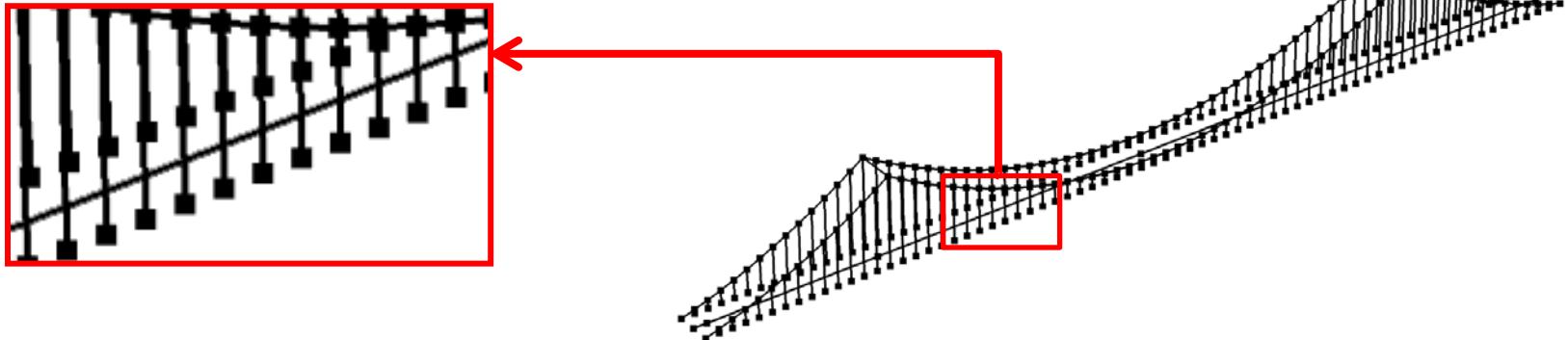

RESULTS - SUSPENDED BRIDGE

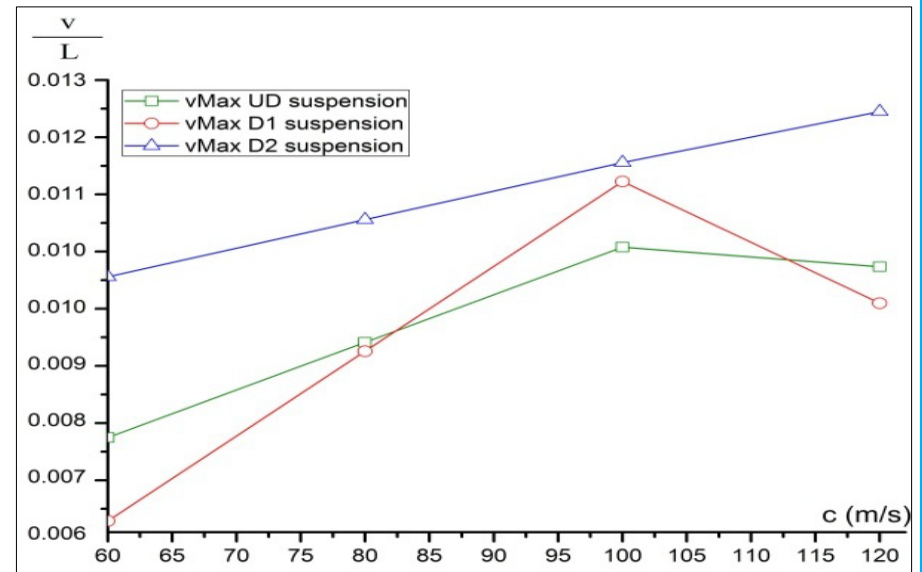
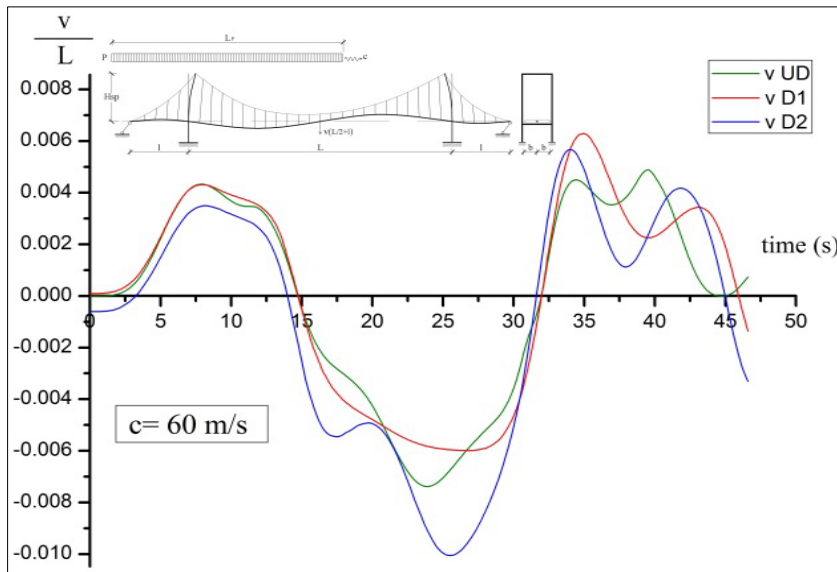

With respect to the undamaged bridge configuration a maximum percentage increment of the maximum displacement equal to 26.66

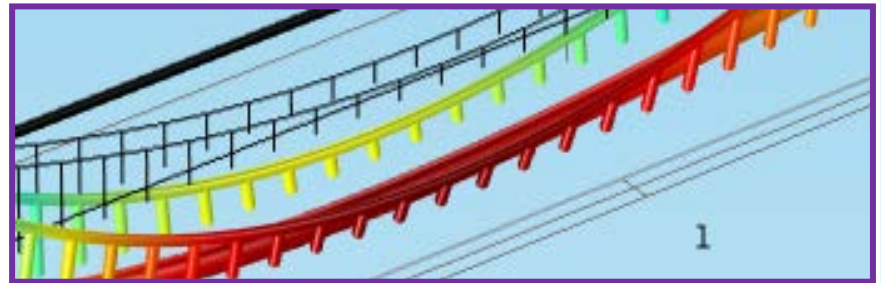

Amplification slightly variable with the speed

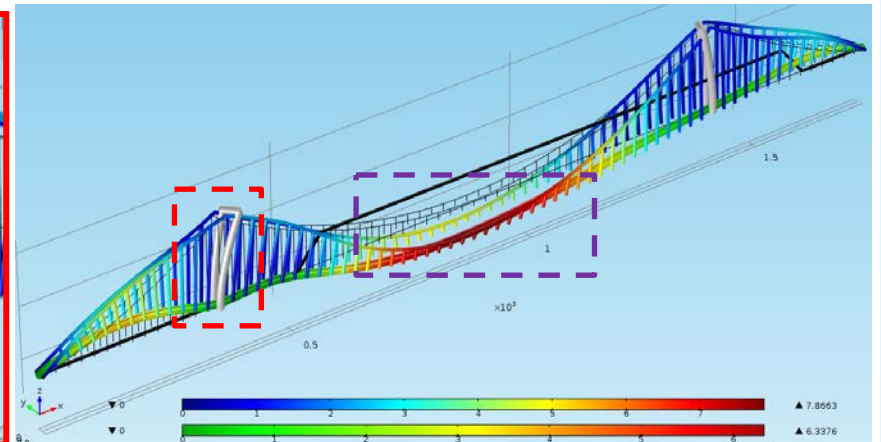

RESULTS - CABLE-STAYED BRIDGE

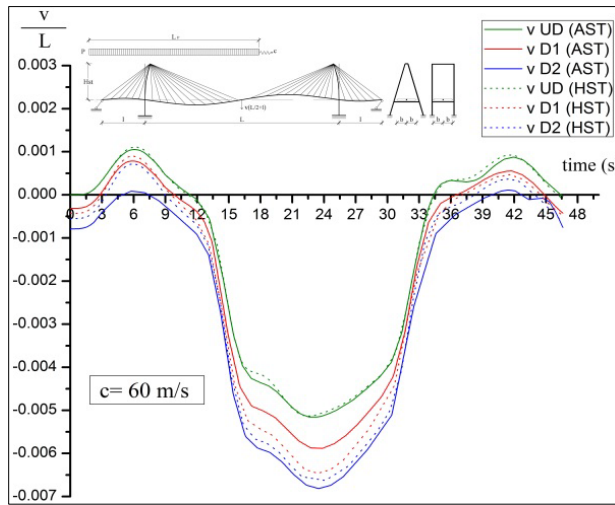

	UD	D1	D2	% Amp. D1	% Amp. D2
H_{shaped}	5.13	5.67	6.92	10.45	34.70
A_{shaped}	5.16	5.72	7.05	10.91	36.66

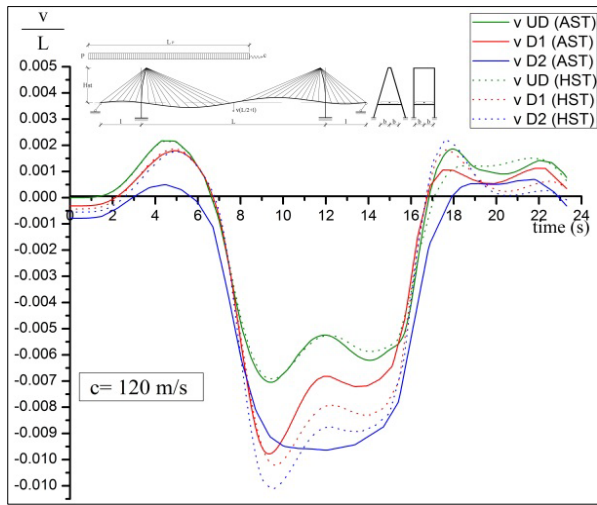

	UD	D1	D2	% Amp. D1	% Amp. D2
H_{shaped}	6.63	8.09	11.1	22.15	67.51
A_{shaped}	6.82	8.16	9.64	19.80	41.43

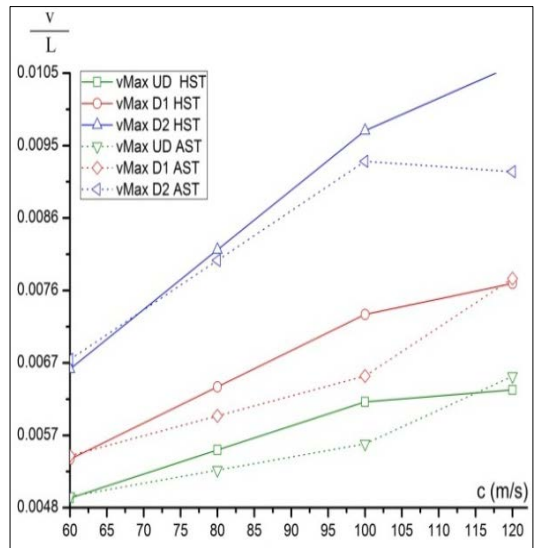

 A partial damage in the anchor cable is able to produce high amplifications of the bridge displacements with respect to the undamaged configuration

 Speed-dependent amplification

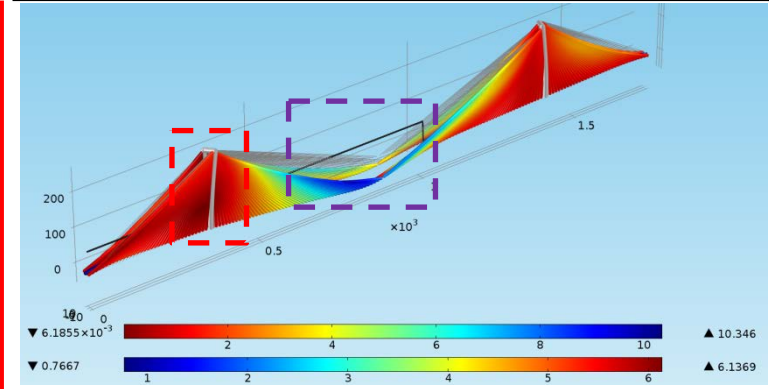
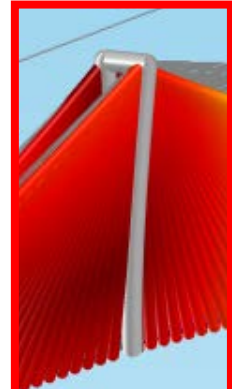
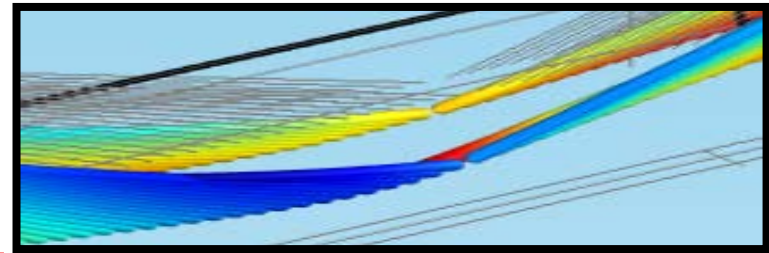

CONCLUDING REMARKS

- ❏ A general model to predict the dynamic response of long span bridges is proposed including the effects of the local vibration of the stays, the damage mechanisms due to corrosion phenomena and moving loads/girder interaction
- ❏ Analysis are developed for cable supported bridges based on both suspension and cable-stayed configurations, adopting similar properties for the main constituents of the bridge structures, i.e. girder, cable system and pylons
- ❏ The bridge deformations are quite dependent for the assumed damage scenario
- ❏ The presence of corrosion in the main cable suspension bridges significantly increases displacements already low-speed
- ❏ In the framework of cable-stayed bridges, the analyses, denote that the presence of a partial damage in the anchor cable is able to produce high amplifications of the bridge displacements with respect to the undamaged configuration
- ❏ Cable-stayed bridges are much more affected by the presence of the damage and the transit speed of the moving loads, since larger values of the bridge displacements with respect to the undamaged configuration are observed